

Taisync

User Manual

www.taisync.cn

Contents

1. Package Contents	1
2. Product Description	4
2.1. Parameters	4
2.2. Air Unit Interfaces	5
2.3. Ground Unit Interfaces.....	6
3. System setup.....	8
3.1. Air Unit Installation	8
3.1.1. Antenna installation	8
3.1.2. Power supply	9
3.1.3. Connect camera.....	10
3.1.4. Connect flight controller (RC & telemetry).....	10
3.2. Ground Unit Installation	11
3.2.1. Antenna installation	11
3.2.2. Power supply	11
3.2.3. Telemetry connection.....	12
3.2.4. Connect remote controller.....	12
3.2.5. Setup video output	13
3.2.6. Use Taisync System	14
4. Software.....	15
4.1. Installation.....	15
4.2. Software Language	18
4.3. Device Info.....	19
4.4. Status	20
4.5. Configuration	21
4.5.1. Downlink Mode configuration.....	22
4.5.2. Baud rate configuration.....	24
4.5.3. Remote control mode configuration	24
4.5.4. Restore default settings	24
4.6. Frequency.....	25
4.6.1. Frequency working mode.....	25
4.6.2. Frequency selection.....	26
4.7. Upgrade.....	26
4.8. Webpage Management.....	27
5. Applications.....	30

5.1.	Applications of Remote Controller	30
5.1.1.	FRSKY remote controller	30
5.1.2.	Futaba remote controller	31
5.2.	Telemetry connection.....	32
5.3.	Get live video	32
6.	Notes.....	32
6.1.	Link performance	32
6.2.	RC link & remote controller	33
6.3.	Firmware update	34
6.4.	Bind operation.....	34
6.5.	PC Windows firewall	35
6.6.	Set PC IP address	35
6.7.	J30J-37 connector pin definition.....	36
7.	FAQ.....	37

1. Package Contents

Air Unit & Ground Unit

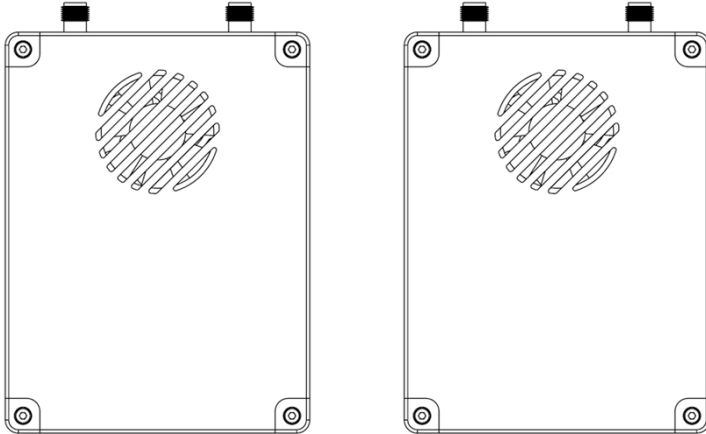

Air unit antenna × 2



Ground unit antenna × 2



Air unit cables

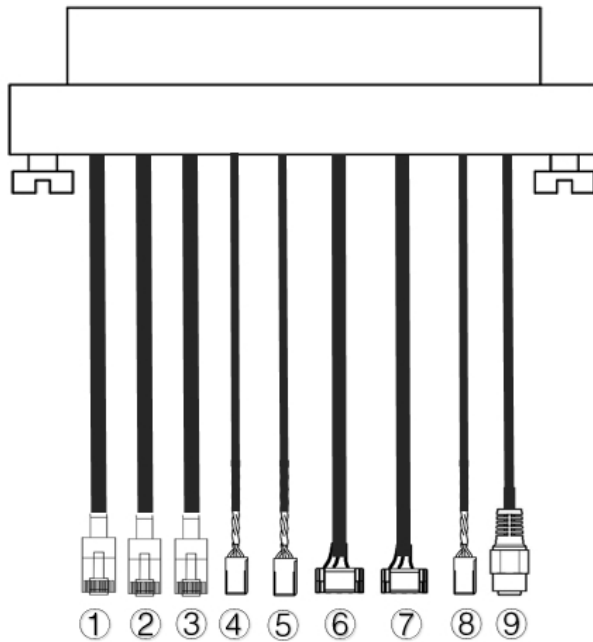

No.	Interface
1,2,3	Ethernet
4,5	S.BUS, as shown in picture, the 1 st pin from the left of dupont connector is S.BUS signal, the 3 rd is G.
6,7	Telemetry serial, as shown in picture, the 2 nd pin from the left of GH1.25 connector is Rx, the 3 rd is Tx, the 6 th is G. (TTL by default, RS232/422 alternative)
8	PPM, as shown in picture, the 1 st pin from the left is PPM signal, the 3 rd is G.
9	Power

Ground unit cables

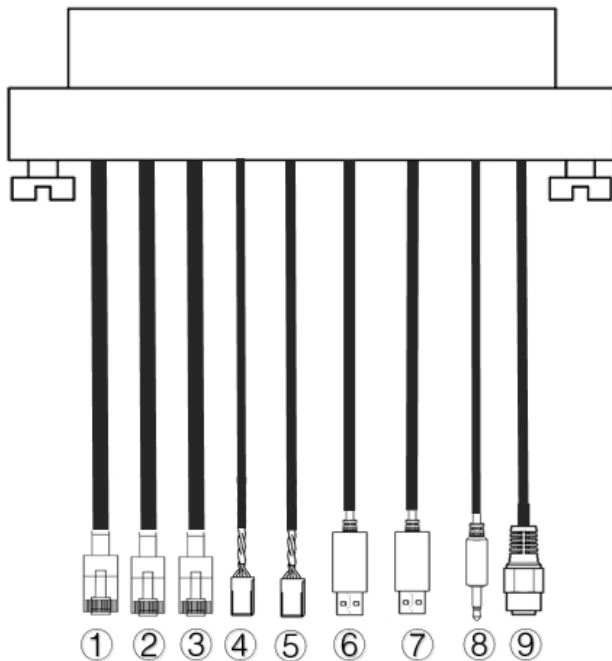

No.	Interface
1,2,3	Ethernet
4,5	S.BUS, as shown in picture, the 1 st pin from the left is S.BUS signal, the 2 nd is 5V+, the 3 rd is G.
6,7	Serial-USB(TTL-USB by default, RS232/422 alternative)
8	PPM
9	Power

2. Product Description

2.1. Parameters

Parameters	Value
Frequency	1330~1450MHz
Band width	10MHz (uplink), 10MHz (downlink)
Power	33dBm
Modulation	OFDM
Constellation	BPSK, QPSK, 16QAM
FEC	LDPC (1/2, 2/3, 3/4, 5/6)
Duplex	TDD
Downlink throughput	2.3Mbps ~ 8bps
Uplink throughput	600kbps
Encryption	AES256 (optional)
Interface	Ethernet, USB, TTL, RS232, RS422, PPM/S.BUS
Power consumption	18W(air unit); 10W(ground unit)
Latency	<300ms (Camera dependent)
Dimension	92.5*70.3*25mm
Weight	198g
Rated voltage/current	DC24V/1.2A (or 6S lithium battery)
Working temperature	-40°C ~60°C

2.2. Air Unit Interfaces

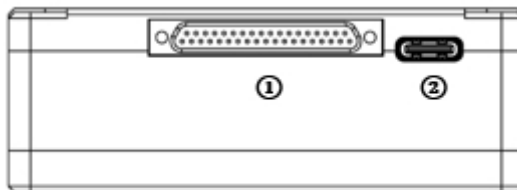

① J30J connector

It's a J30J-37 pin connector providing power/Ethernet/serial/PPM/S.BUS.

② USB Port

Connect this port to the USB port of a PC, and use the Taisync PC program to upgrade firmware and set parameters of the air unit.



① Binding button

Press-and-hold this button to perform the binding operation. Bound already before factory delivery, no need to bind again by user.

② LEDs

From left to right: power indicator (1), Ethernet link indicator (2~4), UL/DL radio link indicator (5~6) not used for air unit. LED6 will be flashing during bind process.

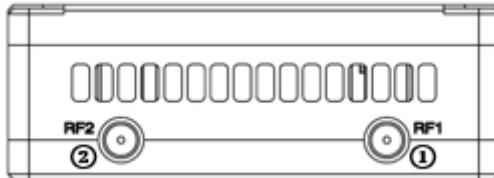

① RF1 Port

Connect the 1st air unit antenna to this port.

② RF2 Port

Connect the 2nd air unit antenna to this port.

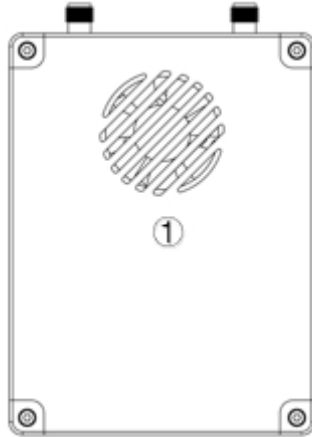

① Fan Ventilation Outlet

Don't block this fan ventilation outlet to ensure effective cooling.

2.3. Ground Unit Interfaces

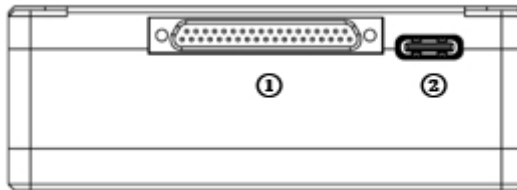

① J30J connector

It's a J30J-37 pin connector providing power/Ethernet/serial/PPM/S.BUS.

② USB Port

Connect this port to the USB port of a PC, and use the Taisync PC program to upgrade firmware and set parameters of the air unit.



① Binding button

Press-and-hold this button to perform the binding operation. Bound already before factory delivery, no need to bind again by user.

② LEDs

From left to right: power indicator (1), Ethernet link indicator (2~4), UL/DL radio link indicator (5~6). LED6 will be flashing during bind process.



① RF1 Port

Connect the 1st air unit antenna to this port.

② RF2 Port

Connect the 2nd air unit antenna to this port.



① Fan Ventilation Outlet

Don't block this fan ventilation outlet to ensure effective cooling.

3. System setup

3.1. Air Unit Installation

3.1.1. Antenna installation

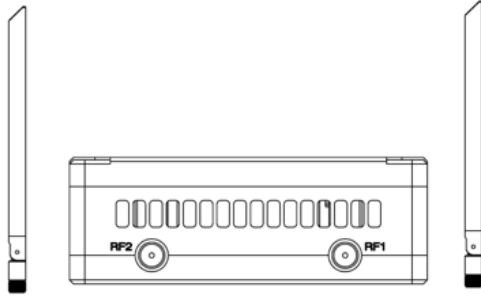

Screw the air unit antennas on the RF ports.

Note:

- (1) To avoid equipment damage, install antennas before powering on the units.
- (2) When mount air unit to drone, make sure the antennas are not both blocked by any part of the drone.
- (3) Both antennas need to be installed.

3.1.2. Power supply

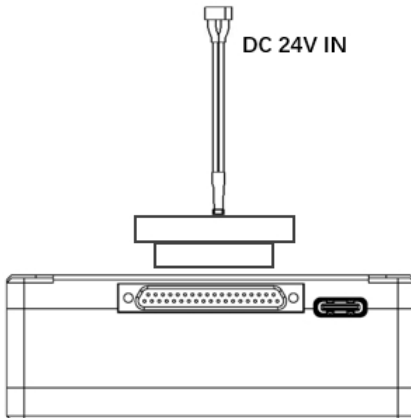

Insert the J30J connector to the J30J port of air unit and connect battery/power source to the power port at the other end.

Note:

- (1) To avoid equipment damage, install antennas before powering on the units.

(2) Recommended rated voltage/current is DC24V/1.2A (or 6S lithium battery).

3.1.3. Connect camera

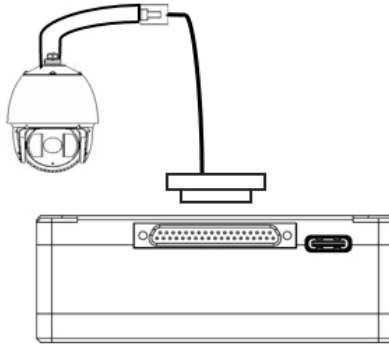

Connect the video output port of the IP camera to the Ethernet video input port of the air unit.

3.1.4. Connect flight controller (RC & telemetry)

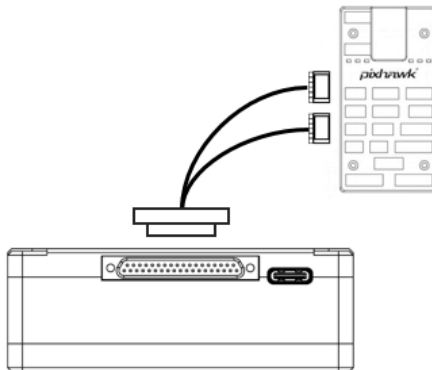

Insert the J30J connector to the J30J port of air unit and connect the other end of the serial cable to the telemetry port of a flight controller.

Insert the J30J connector to the J30J port of air unit and connect the other end of the RC cable to the PPM/S.BUS port of a flight controller.

3.2. Ground Unit Installation

3.2.1. Antenna installation

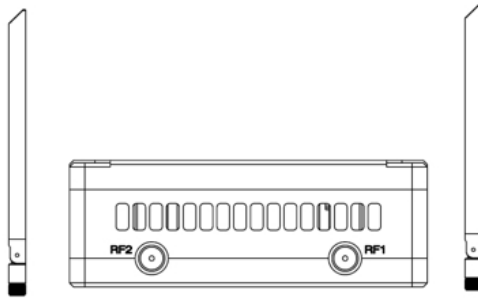

Screw the ground unit antennas on the RF ports.

Note:

- (1) To avoid equipment damage, install antennas before powering on the units.
- (2) Both antennas need to be installed.
- (3) Adjust the antenna to be vertical to the ground during operation.

3.2.2. Power supply

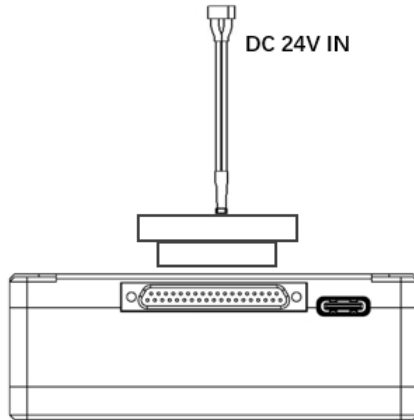

Insert the power connector of a power source into the power port of the ground unit

Note:

- (1) Recommended rated voltage/current is DC12V/1.2A (or 3S lithium battery).
- (2) To avoid equipment damage, install antennas before powering on the units.

3.2.3. Telemetry connection

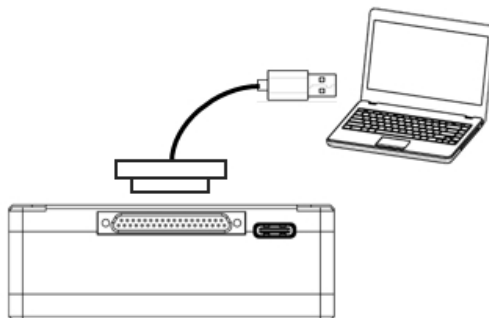

Insert the J30J connector to the J30J port of ground unit and connect the other end of supplied serial cable to the telemetry port of the ground control station.

Note:

- (1) Ensure the baud rate of ground station and the baud rate of Taisync module are configured to be the same.

- (2) Ensure the serial cable sequence matches the interface definition of Taisync module.

3.2.4. Connect remote controller

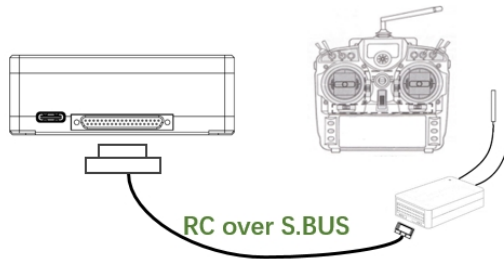
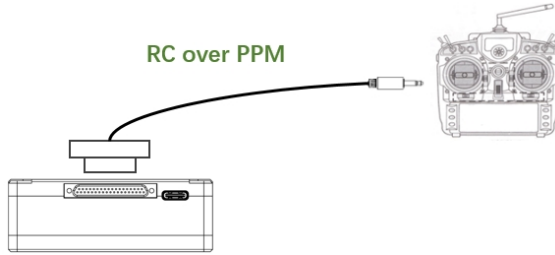

Using PPM mode: Insert the trainer port connector of the supplied RC cable to the trainer port of a remote controller and Insert the J30J connector to the J30J port of ground unit.

Using S.BUS mode: Insert the J30J connector to the J30J port of ground unit, connect the other end to a S.BUS receiver, and the S.BUS receiver communicates with the remote controller wirelessly.

Note:

- (1) Ensure the RC cable's pin-out matches the interface pin-out of Taisync module.
- (2) If a S.BUS receiver is used, there should be enough guard band between the working frequency band of the receiver and the working frequency band of Taisync module.

3.2.5. Setup video output

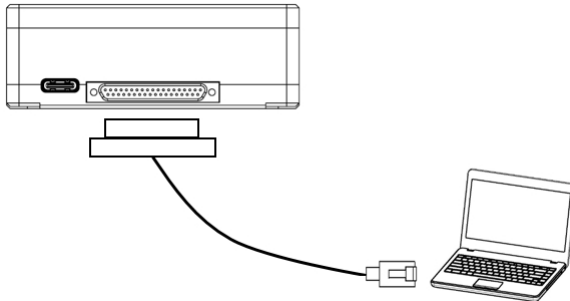

Insert the J30J connector to the J30J port of ground unit and connect the other end of supplied Ethernet cable to PC or the ground control station. Make sure IP addresses of camera and PC are in the same subnet.

3.2.6. Use Taisync System

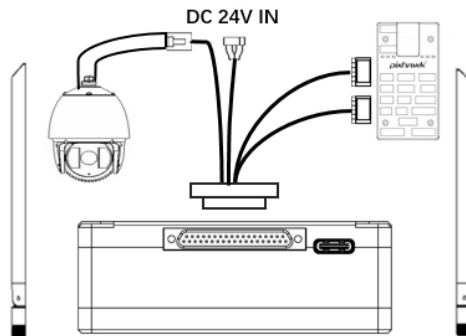

1. Install antennas to the air unit.
2. Connect IP camera output to Ethernet port of the air unit.
3. Connect the PPM/S.bus port of the flight controller to the RC port of the air unit.
4. Connect the telemetry port of the flight controller to the serial port of the air unit.
5. Connect a 24V DC power source to the power port of the air unit and turn it on.
6. If the latest firmware is needed, connect the air unit to a PC using USB cable and run Taisync PC program to upgrade the firmware of the unit to the latest one.

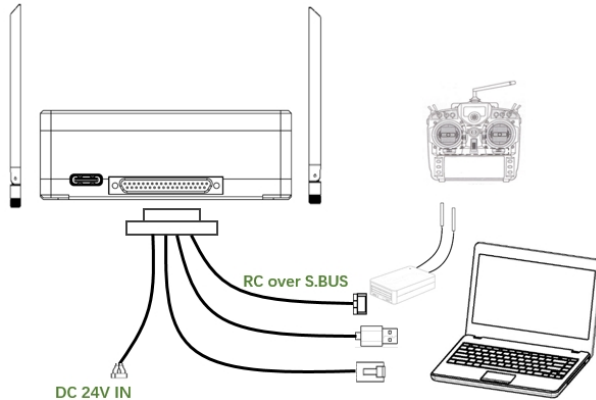

1. Install antennas to the ground unit.
2. Configure the remote controller to be in trainer mode. If PPM mode is used, connect the remote controller interface of the ground unit to the trainer port of the remote control. If S.BUS mode is used, a S.BUS receiver needs to be connected to the ground unit using supplied cable, and the connection between the S.BUS receiver and the remote controller need to be established.
3. Connect the USB port of a ground control station to the serial port of the ground unit through a Serial-2-USB adaptor to use telemetry link.
4. Connect the Ethernet port of a GCS or PC to the RJ45 connector of ground unit to get IP video/telemetry (telemetry over Ethernet).
5. Turn on the ground unit.
6. If the latest firmware is needed, connect the ground unit to a PC using USB cable and run Taisync PC program to upgrade the firmware of the unit to the latest one.
7. After downlink and uplink are established, both LEDs of the ground unit will be on.

4. Software

4.1. Installation

Taisync provide program installation files, program file name: Taisync Wireless App Setup.exe. The installer icon is as following:

Taisync ViuLinux Setup V3.14.1.exe

Double-click the installer to install and customize the program installation directory. After configuration, click “Next” to move to the next step. To cancel the installation, click “Cancel”.

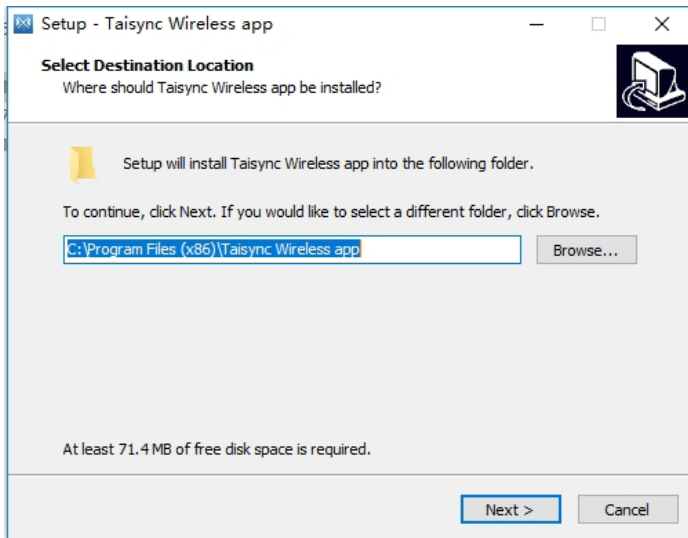

Check the “Create desktop shortcut” if desktop shortcut is needed. If it is not checked, the desktop shortcut will not be created. After configuration, click “Next” to move to the next step. To go back to the previous step, click “Back”. To cancel the installation, click “Cancel”.

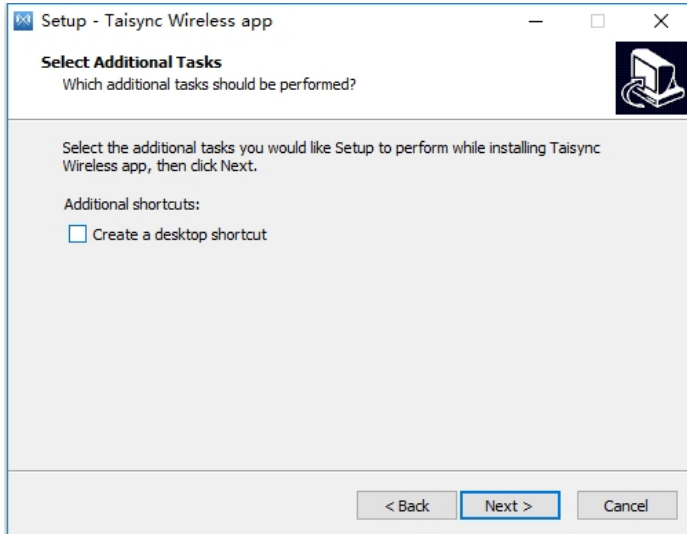

Click “Install” to proceed with the installation. To go back to the previous step, click “Back”. To cancel the installation, click “Cancel”.

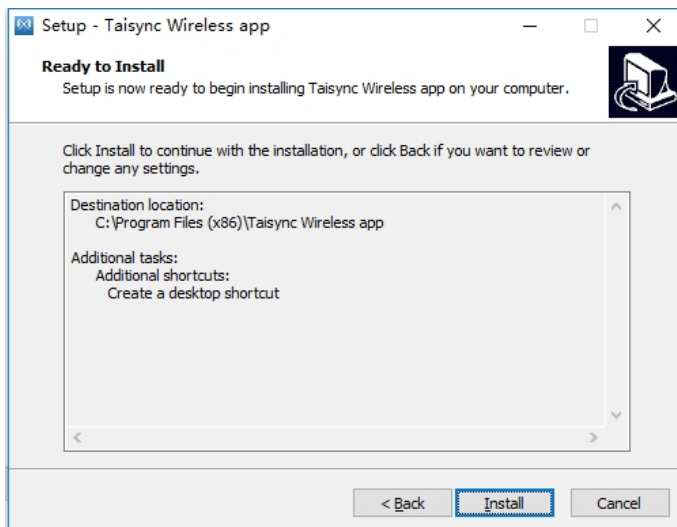

Note: Please disable the anti-virus software, otherwise the anti-virus may prevent the driver from being installed during the driver installation.

At this point, the software installation is done and the driver installation is completed.



4.2. Software Language

Taisync PC software supports both Chinese and English.

The software will display in Chinese if the operating system of the PC is in Chinese, otherwise the software displays in English.

If the device is not connected to the computer properly, Taisync PC software shows the following picture:



Please connect device

If the device is connected to the computer properly, Taisync PC software shows the following picture:



	Device Type	Ground
	Software Version	V3.1E
	Firmware Version	3.1.3
	Baseband Version	200513

SN: ■■■■■■■■■■-c200513-a2005113-13512-D_OIU_4.0.0

4.3. Device Info

Information on the homepage: device type, software version, firmware version, and baseband version.

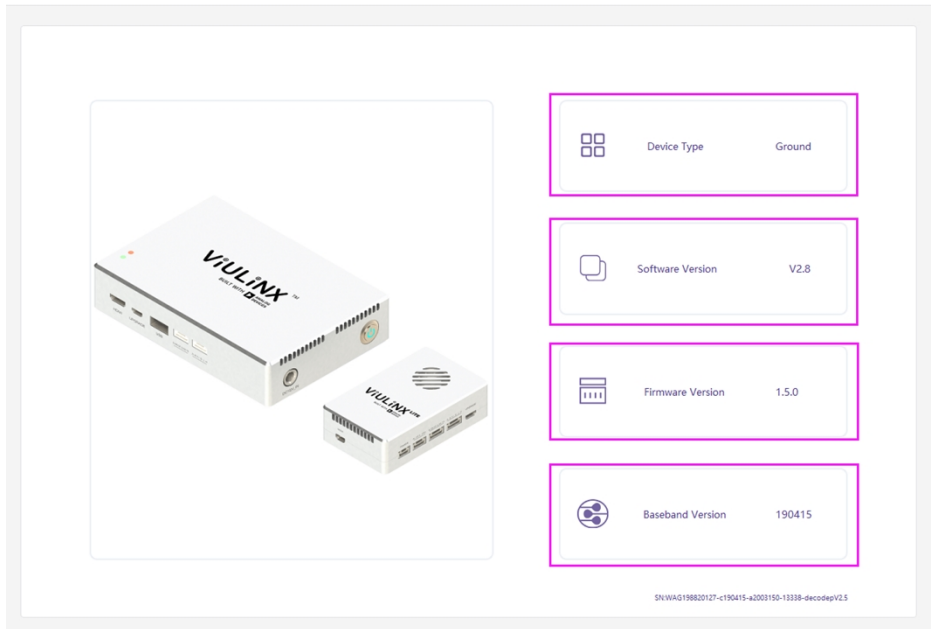

4.4. Status

Read the status information of air unit and ground unit under “Status” page section:

Air: RSSI 1 & RSSI 2, Uplink rate, Distance, BB TEMP, PA TEMP.

Ground: RSSI 1 & RSSI 2, Downlink rate, SNR, BB TEMP, PA TEMP.

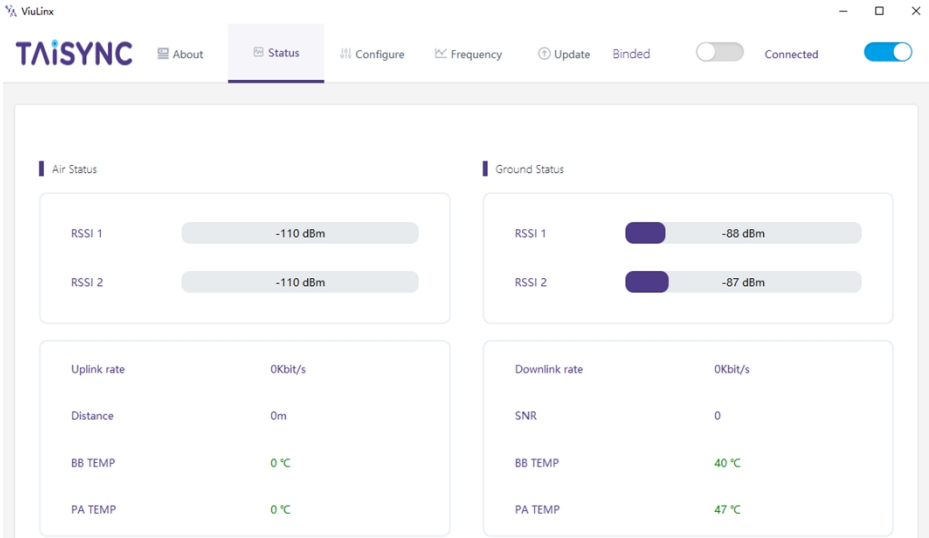

4.5. Configuration

To change configuration, device need to be bound and wireless connection between air unit and ground unit needs to be established.

Usage

Parameters can not be modified unless the air unit is paired with the ground unit.

Pairing procedure

- 1.Put air unit into pairing state;
- 2.Put ground unit into pairing state;
- 3.Wait for 10 seconds and power off both units;
- 4.Power on both units, pairing is successful if there is no error message.

DownLink

QPSK_1/2 (3.97Mbps)

Uart Baud Rate

115200b

RC Mode

PPM

S.Bus

Restore default settings

Restore

4.5.1. Downlink Mode configuration

To change downlink mode, device need to be bound and wireless connection between air unit and ground unit needs to be established

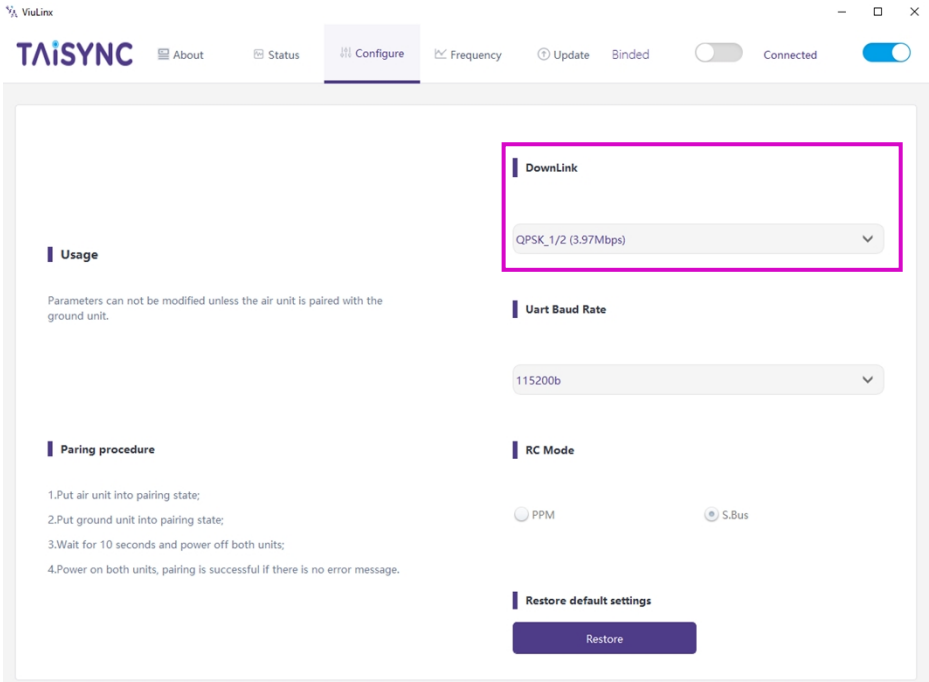

There are 8 options for downlink mode from the drop-down menu (see the following screenshot):

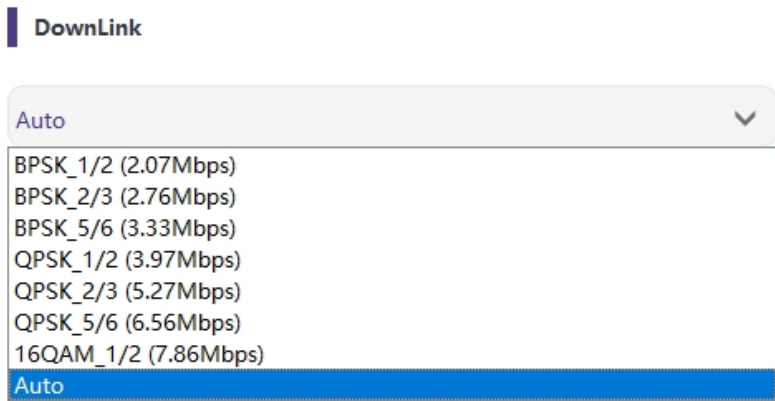

When it's selected as Auto, modulation scheme will be dynamically adaptive based on real-time signal quality.

4.5.2. Baud rate configuration

There are 4 options for serial port baud rate (see the following screenshot).

Uart Baud Rate

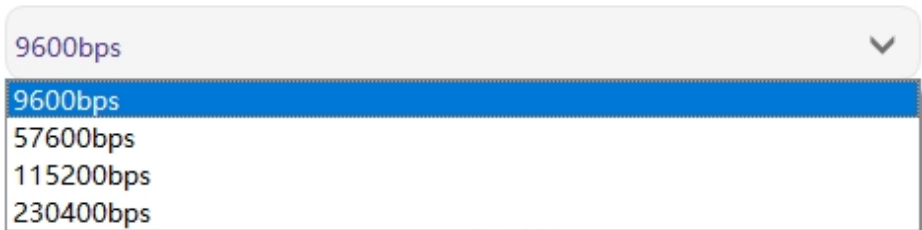

4.5.3. Remote control mode configuration

There are two options for remote control mode, PPM and S.BUS (see the following screenshot).

RC Mode

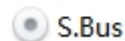
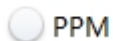

4.5.4. Restore default settings

Click “Restore” to restore default settings.

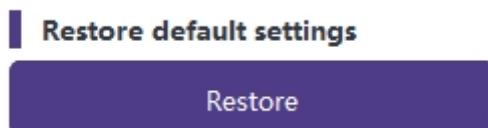

4.6. Frequency

Frequency related information/parameters can be checked/set at page of frequency.

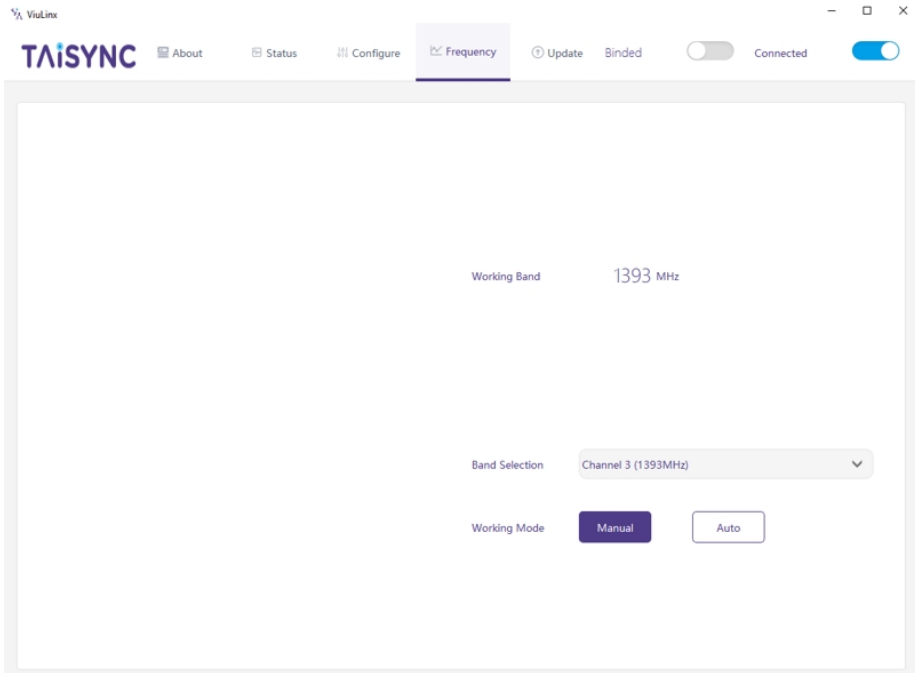

4.6.1. Frequency working mode

Working Mode : Manual, Auto.

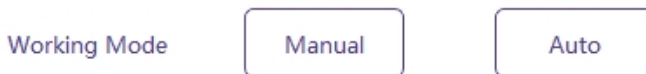

Manual mode: The user manually selects the working frequency.

Auto mode: The system selects the working frequency based on the frequency scanning.

4.6.2. Frequency selection

Under the manual mode, working frequency can be selected from the drop-down menu. Please select and use the channels in accordance with the product specification (1330~1450MHz).

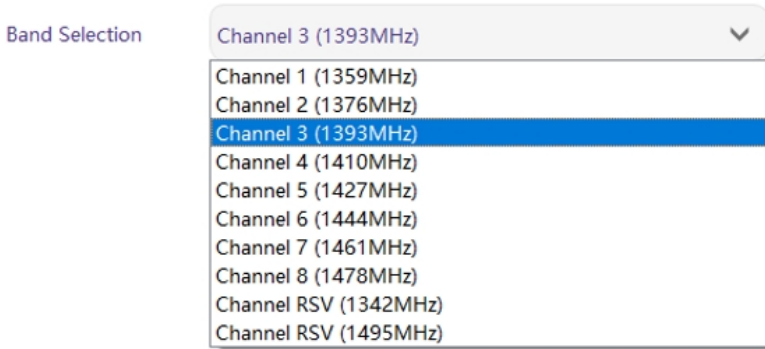

4.7. Upgrade

Note: air unit and ground unit need to be upgraded separately using the USB cable to connect Taisync PC software.

Goes to the Upgrade page. Select the upgrade file, click the “Upgrade” purple button to upgrade.

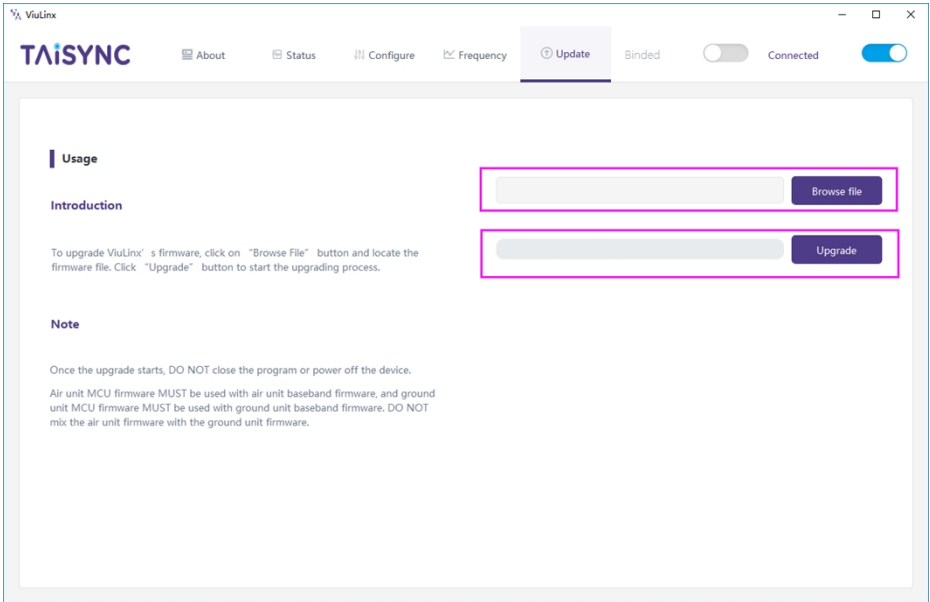

4.8. Webpage Management

Besides PC app management via USB, webpage management via Ethernet is also supported. Directly connect PC to air unit/ground unit by Ethernet cable, set PC IP address as 192.168.199.33/24, and visit 192.168.199.18 (air unit)/192.168.199.16 (ground unit) through webpage.

Under Status→Baseband status, there's detailed information like RSSI, SNR, TxPower, LDPC stats, telemetry stats, etc.

Status	Config	Upload	
Baseband Status			
Device Information			
Baseband Status			
A-LdpcPass	35483	G-LdpcPass	668848
A-LdpcFail	22	G-LdpcFail	98
A-Snr	27	G-Snr	31
A-RSSI0	-37	G-RSSI0	-20
A-RSSI1	-24	G-RSSI1	-24
A-RxVga0	13	G-RxVga0	-3
A-RxVga1	4	G-RxVga1	0
A-TxPower	13	G-TxPower	0
A-LinkStatus	track	G-LinkStatus	track
A-LinkQuality	100%	G-LinkQuality	100%
A-FPGATemp	49	G-FPGATemp	46
A-AD9381Temp	42	G-AD9381Temp	34
A-CurrentAvt	auto-rf2	G-CurrentAvt	auto-rf1
A-TxOverflowCnt	0	G-TxOverflowCnt	0
A-TxErrorCnt	1163	G-TxErrorCnt	512
A-TxCnt	1163	G-TxCnt	512
A-RxSublinkCnt	73	G-RxSublinkCnt	75
A-RxDiscardCnt	0	G-RxDiscardCnt	0
A-RxRepeatCnt	0	G-RxRepeatCnt	0
downlinkDataRate	0kbs	uplinkDataRate	0kbs
Bind Status	bind	U1-Rx0Byte	0
Distance	0	U1-SendByte	811078
UAV	online	U2-Rx0Byte	0
slvsRxCnt	0	U2-SendByte	0
ppmRxCnt	0	MCS	16QAM_1_2(7.8Mbaud)

Under Status→Device information, there's information of SN and firmware version.

Status	Config	Upload
Baseband Status		
Device Information		
Device Information		
SN	GN0123456789	
version	C26219701-22011350	
FirmwareVersion	3.5.0_2_26219709	
BasebandVersion	20210701	

Under Config→Net settings, there're IP address of unit itself, telemetry destination IP address and UDP ports, all of these parameters can be changed as per user's request.

Status	Config	Upload
Net Settings		
Net Settings		
IP Address	192.168.199.16	
Subnet Mask	255.255.255.0	
Mavlink Host IP	192.168.199.33	
Mavlink UDP Port	14550	
Mavlink UDP Port Ext	14551	
	<input type="button" value="set"/>	

Under Config→Radio settings, there're hop, frequency, antenna selection can be set. When hop is auto, user do not need to/cannot set frequency, system dynamically selects the best frequency to use by itself, in other words, when hop is manual, user can set frequency manually.



Under Config→Bind setting, bind process can be triggered by clicking bind instead of physical bind button.

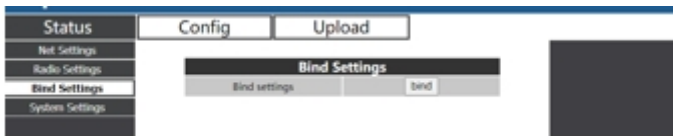

Under Config→System settings, baud rate for U1/U2 two serial ports can be set. When QAM mode is set as adaptive, unit will dynamically change modulation scheme based on real-time signal quality. Role of pilot has bi-directional transmission while observer only has downlink data.

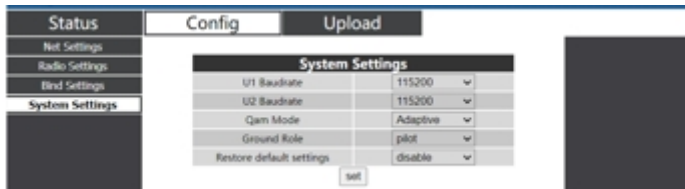

Under Upload→Upload, browser and select file to be upgraded first, then click send to trigger the process.



5. Applications

5.1. Applications of Remote Controller

Taisync modules support PPM and S. BUS protocol.

If PPM mode is used, please use Taisync standard PPM cable to connect the ground unit and the remote controller's trainer port.

If S. BUS mode is used, additional S.BUS receiver is needed. The ground unit is connected to the receiver. Then S. BUS receiver establishes wireless communication with the remote controller.

Both modes require the remote controller to be configured to the corresponding working mode.

If S. BUS receiver is used, please use a receiver whose working frequency is different from that of Taisync module.

When PPM mode is used, the air unit needs to connect to the PPM RC port of a flight controller.

When S. BUS mode is used, the air unit needs to connect to the DSM/S. BUS RC port of a flight controller.

5.1.1. FRSKY remote controller

PPM mode

Model setup - Trainer – mode: If mode is configured to Slave/Jack, then the remote controller is in PPM mode.

Model setup - Internal RF: It needs to be configured to be off, and S. bus mode will be disabled.

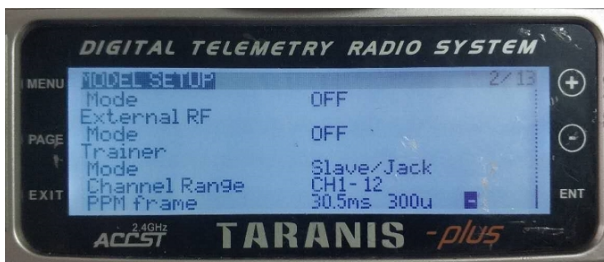

✚ S.BUS mode

Model setup - Internal RF: LR12, D8, D16, OFF. Configuration of different parameters follow those of the receiver. If configured as OFF, S. bus mode will be disabled.



5.1.2. Futaba remote controller

✚ S.BUS mode

Linkage menu - system: FASSTest-14CH, FASSTest 12CH, FASST MULTI, FASST 7CH, S-FHSS. Configuration of different parameters follow those of the receiver.

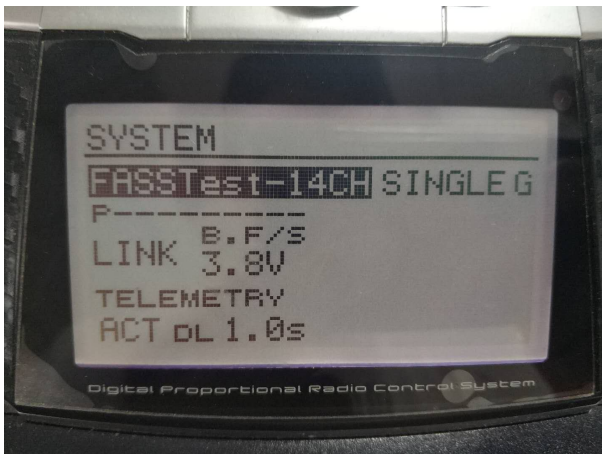

✚ PPM mode

Taisync standard PPM cable is used to connect to Futaba trainer cable (one end is connected to the trainer port of Futaba controller, the other end is 3.5mm connector). PPM mode can be used directly without additional configuration.

5.2. Telemetry connection

The telemetry Port of air unit connects “TELEM1” Port of a flight control (Pixhawk4).

5.3. Get live video

Get real-time video through RTSP on media players like QGC/VLC. Make sure IP addresses of PC and camera are in the same subnet.

6. Notes

6.1. Link performance

- RF cable connector/Antenna connector check

Before flight, check if the antennas are connected to the modules. Running module without antennas connected results in very short range and can potentially damage the module. It is recommended to check the connection of all RF connectors. Loose connection can degrade the range significantly.

- Antenna placement

Place the two air antennas so that no matter what position the drone is, at least one antenna is not blocked by the payload from the ground station.

If the drone will fly in full throttle, it will lean forward. Install the air antenna so that it is close to be vertical to the ground when the drone moves forward in full throttle.

- Battery level

The reception performance will degrade if the battery runs low, even though it might still power the units up.

6.2. RC link & remote controller

The RC link of Taisync module supports the PPM and S.BUS protocols. If the PPM protocol is used, you need to configure the remote controller to PPM mode and turn off the wireless transmission of the remote controller. If the S.BUS protocol is used, the wireless working frequency of the receiver connected to the remote controller must work in different frequency bands with the working frequency of Taisync module and have a certain isolation guarantee. If you do not use the RC link of Taisync module, you should pay attention to the remote link working frequency of the remote controller when using the RC link of the remote controller. If it is in the same frequency band as the working frequency of Taisync module, it will cause interference with each other.

Avoid interference with Taisync module by the wireless link of the remote controller or receiver when using Taisync system.

6.3. Firmware update

Upgrade files: FPGA upgrade file for air unit, FPGA upgrade file for ground unit, MCU1 upgrade file for air unit, MCU1 upgrade file for ground unit, MCU2 upgrade file for air unit, MCU2 upgrade file for ground unit.

Upgrade files are upgraded using Taisync PC software. During the upgrade, the power cannot be powered off and the normal connection of USB cable should be ensured at the same time. If the upgrade fails, the power cannot be powered off, please try to upgrade again directly. Otherwise, it will be necessary to return to us to use special burning tools for firmware burning.

6.4. Bind operation

“Bind” is used to pair an air unit with ground unit.

To pair an air unit and a ground unit:

1. Both air unit and ground unit are powered on.
2. Connect the air and ground unit.

3. Press the physical bind button of the air unit, last 5s+. The LED light next to the bind button flashes green, indicating that it is in the binding state.
4. Press the physical bind button of the ground unit, last 5s+. The LED light next to the bind button flashes green, indicating that it is in the binding state.
5. When the link indicator LEDs of ground unit are always on, it indicates that the air and ground unit is bound.

Note:

- (1) If modules binding with different firmware version, the binding operation may fail.
- (2) If the program of the air unit or the ground unit is burned incorrectly, such as burning the air unit to the ground unit, and performing the binding operation between the wrong air unit and the ground unit, the binding operation will fail.
- (3) Units are bound already before factory delivery, customer do not need to bind again after unboxing.
- (4) If unit is restored to factory setting, bind again is needed.

6.5. PC Windows firewall

Make sure PC firewall is disabled in case video and/or telemetry is blocked. Here take Windows10 operation system for reference. Path: Control Panel\System and Security\Windows Firewall\Customize Settings.

Set Private/Public network settings as 'Turn off Windows Firewall' as below, click 'OK'.

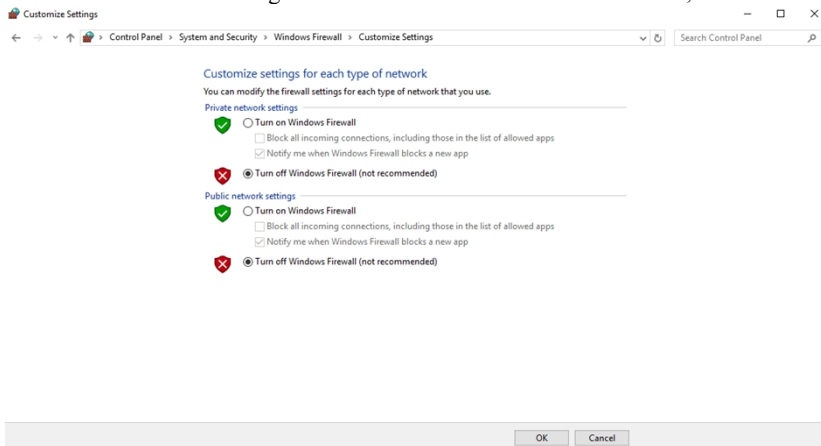

6.6. Set PC IP address

PC IP address should be set correctly when watch video in PC, IP address can be set following below steps:

Double click 'Ethernet' at Control Panel\Network and Internet\Network Connections,

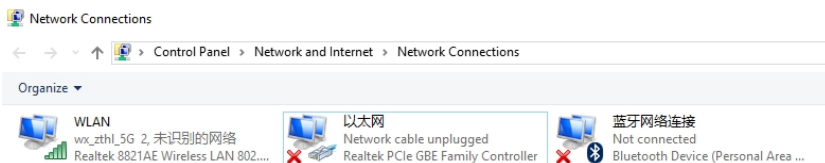

Double click 'Internet protocol version 4(TCP/IPv4)', set PC IP address like below, click 'OK' finish.

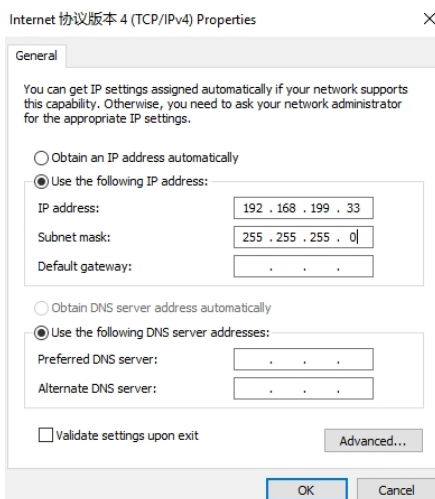

6.7. J30J-37 connector pin definition

Name	Pin
Power	1,2,20
GND	3,10,15,21,22,29,31
Ethernet1 TX+	7
Ethernet1 TX-	26

Ethernet1 RX+	6
Ethernet1 RX-	25
Ethernet2 TX+	5
Ethernet2 TX-	24
Ethernet2 RX+	4
Ethernet2 RX-	23
Ethernet3 TX+	8
Ethernet3 TX-	27
Ethernet3 RX+	9
Ethernet3 RX-	28
SBUS_V	11
PPM	12
GPS_SYNC	13
Reserved	14
232TX1 or 422Y2	16
232RX1 or 422A2	17
232TX2 or 422Y1	18
232RX2 or 422A1	19
SBUS1	30
SBUS2	32
Reserved	33
422Z2 or TTLTX1	34
422B2 or TTLRX1	35
422Z1 or TTLTX2	36
422B1 or TTLRX2	37

7. FAQ

Q1: How does the Taisync module supply power?
Air unit: DC, power supply range: 9-26V, recommended to use 24V.
Ground unit: DC, power supply range: 9-26V, recommended to use 24V.
Q2: Can the Taisync module be powered on before antennas installation?
The antennas must be installed before power on.
Q3: How many antennas do Taisync's air unit need to be installed?
Two antennas need to be installed.
Q4: How many antennas do Taisync's ground unit need to be installed?
Two antennas need to be installed.
Q5: Can different types of remote controllers be used to control drone?
Yes, just output standard PPM signals through the coach port, or use S. BUS receiver.
Q6: Can two air units be installed on a drone?
No, a drone can only have one air unit.
Q7: Can two ground units be installed at the receiving end?
The ptp system can only install one ground unit; the ptmp system supports more than one ground units.
Q8: What if the uplink/downlink LED indicator is not on?
Please follow the following steps:
1) Please check the power supply of the air and ground unit is normal.
2) Please check the antennas installation of the air and ground units is normal: whether the antennas is blocked; whether the antennas connection is loose; whether the RF cable and port is not tightened;
3) Check whether the TX frequency of the ground unit is consistent with the RX frequency of the air unit with Taiysnc PC App.
4) Check the TX power of the ground unit with Taiysnc PC App.
5) If above steps cannot solve the problem, please contact Taisync technical support staff.
Q9: Telemetry connection cannot be setup properly?
Please follow the following steps:

1) Please check whether the link status is normal.
2) Please check whether the serial telemetry cable connection between flight controller and air unit is correct and that between ground unit and ground station is correct.
3) Check whether the baud rates are the same.
4) If above steps cannot solve the problem, please contact Taisync technical support staff.
Q10: RC connection cannot be setup properly?
Please follow the following steps:
1) Please check whether the link status is normal;
2) Please check whether the RC connecting between flight controller and air unit is correct and that between ground unit and remote controller is correct;
3) If using PPM mode, check the mode configuration of the remote controller; if using S. BUS mode, check the configuration of the receiver and remote controller;
4) Please check whether the RC connection of the air and ground unit is correct. We provides standard cables. If you make it by yourself, please check the pin;
5) Please check whether the RC mode is configured correctly in Taisync app;
6) If above steps cannot solve the problem, please contact Taisync technical support staff.
Q11: What if there's no video output?
Please follow the following steps:
1) Please check whether the link status is normal;
2) Please check whether the Ethernet cable and camera is normal;
3) Please check whether the RTSP address is correct;
4) Please check whether PC IP address and camera IP address are in the same subnet;
4) If above steps cannot solve the problem, please contact Taisync technical support staff.
Q12: What if the video suffers from distortion?
Please follow the following steps:

1) Please confirm whether the downlink mode configuration is larger than the video bit rate;
2) Please check whether the Ethernet connection of air unit cable is reliable;
3) Whether the connection of Ethernet cable of ground unit is reliable;
4) Please check If there is interference exists, change the working frequency if need;
5) If there is no interference, whether the limit distance of communication link has been reached;
6) If above steps cannot solve the problem, please contact Taisync technical support staff.
Q13: What if the transmission distance of the module is shorter than expectation?
Please follow the following steps:
1) Please verify whether the antenna and RF cable are installed correctly and check whether they are supplied Falcon accessories.
2) Please ensure that the air antennas are not both blocked by the payload, there is no obvious blocking at the ground unit near the antennas, and the antennas of the air and ground units are perpendicular to the ground.
3) Please check whether the module works with full RF power output.
4) Please check whether the downlink mode configuration is proper or not, the high throughput downlink modes can significantly reduce the transmission distance.
5) Please check whether the working frequency is obviously interfered or not.
6) Please check whether there is serious obstruction between the air and the ground unit during flight, and the complex geographical environment will also affect the transmission distance.
7) If above steps cannot solve the problem, please contact Taisync technical support staff.